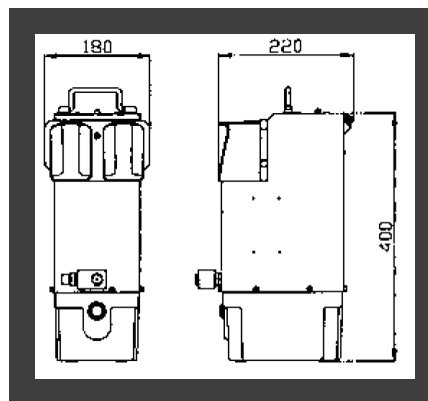

Battery Hydraulic Pump with Hose

ARTICLE #

470.700.11

Model

LANTARO -P2

Specification

Motor	Oil Pressure	Max. Pressure	Min. Pressure	Reservoir Volume	Dimension (mm)	Weight (kg)
DC 28.8V	700kgf/cm ²	0.3 liter/min	1.8 liter/min	1700c.c.	400(L)*220(H)*180(W)	16.3

Accessory

Charger & Battery, 1.8M Hose, Remote Control Switch

 00491 5781 123799

Address : Travaza Tools

Amtsgericht Koblenz 56068 koblenz, Solver GMBH, Furst-Abtissinnen-Strabe 6, 53498 Bad Breisig

 www.travazatools.com